

## PUREPOWER SERIES PP650

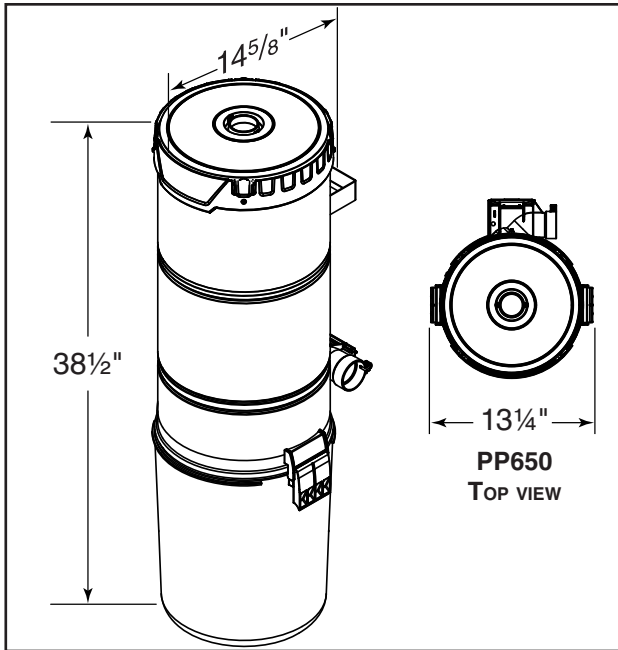

### SPECIFICATIONS

Motor . . . . .	1-Stage
Horsepower . . . . .	2.35 @ Full open orifice
Amperes . . . . .	13.5
Voltage . . . . .	120 VAC
Water Lift . . . . .	130"
Air Watts . . . . .	650
Switch on Power Unit. . . . .	Yes
Recommended Circuit . . . . .	Minimum 20 Amps
Filtration Type . . . . .	Sealed HEPA 2.0
Capacity . . . . .	6 U.S. Gallons
Filtration Level . . . . .	HEPA
Quietness . . . . .	65 dB
cULus Listed . . . . .	Yes
Housing . . . . .	Metal housing with polymeric debris pail
Dimensions. . . . .	13 1/4" W x 14 5/8" D x 38 1/2" H

Designed for homes up to 9,000 ft.<sup>2</sup>, this power unit features a 1-stage motor that delivers 650 air watts of power.

### FEATURES

- Sealed HEPA 2.0 featuring HEPA filter with glued seams and a secondary HEPA filter provide unmatched filtration for cleanest indoor air
- ULTRA Silent™ Technology: Among the quietest in the industry; no muffler required
- FlexCollect debris disposal - Hybrid bagging system offers bagged & bagless options in 1 unit
- Large 6 U.S. gallon easy-clean, corrosion resistant debris pail that typically needs emptying only every 6 months
- Oversized debris pail handles made for a quick and easy pail removal
- Utility valve included
- Wall mounted bracket for simple, safe and secure mounting
- Six foot long power cord
- cULus Listed
- 10-Year limited warranty



Broan-NuTone LLC, 926 West State Street, Hartford, WI 53027 (1-888-336-6151) www.nutone.com

Project:	REMARKS
Location:	
Model no.:	
Quantity:	
Submitted by:	
Date:	